



厦门贯宇电子科技有限公司
Xiamen Kuan Yi Electronic Technology CO.,Ltd.

Shear Beam Load Cells SQB with Static I type Weighing Module



Application:

For Material tower

The weighing module is installed under the foot of the tower, and the weighing system is used to achieve precise ingredients.

Features:

Simple structure and easy installation

Mounting height adjustable

Suitable for static tank weighing not so high precision requirements

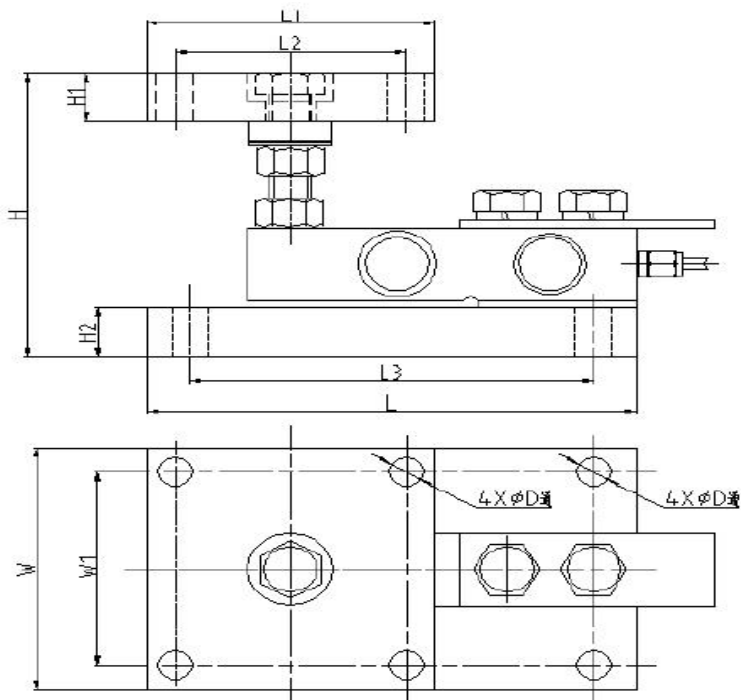

量程	尺寸	L	L1	L2	L3	H	H1	H2	W	W1	D
0.5~2.5t		180.9	127	101.6	152.4	100~120	18	18	127	101.6	16
3~5t		215.9	127	101.6	177.8	130~150	26	26	127	101.6	16
7.5~10t		266	170	127	239	180~200	34	34	170	127	22

Specification

Application	Platform Scales , Floor Scales , Blending Scales
Rated Load	0.25, 0.3, 0.5, 0.75, 1, 1.5, 2, 2.5, 3, 5, 7.5, 10t
Sensitivity	3±0.003mV/V (0.5-10t) , 2.0±0.002mV/V(0.25-0.3t)
Accuracy Class	C2-C5
Zero balance	±1%F.S ±0.02%F.S/10°C
TCO	±0.02%F.S/10°C
TC SPAN	±0.02%F.S/10°C
Input resistance	400±10Ω
Output resistance	352±3Ω
Insulation resistance	≥5000MΩ
Temperature Range. Compensated	-10~+40°C
Operating Temp Range	-30~+70°C
Safe load limit	120%F.S
Over load limit	180%F.S
Recommend excitation	10~12V DC
Maximum excitation	15V DC
Protection Class	IP67(0.25-0.75t) IP68 (1-10t)
Construction	Alloy Steel/Stainless Steel
Cable: Length;	3m(0.25-2.5t),4.2m (3-5t), 5m(7.5-10t)
	Diameter:Φ5mm(0.25-5t), Φ6mm (7-10t)