

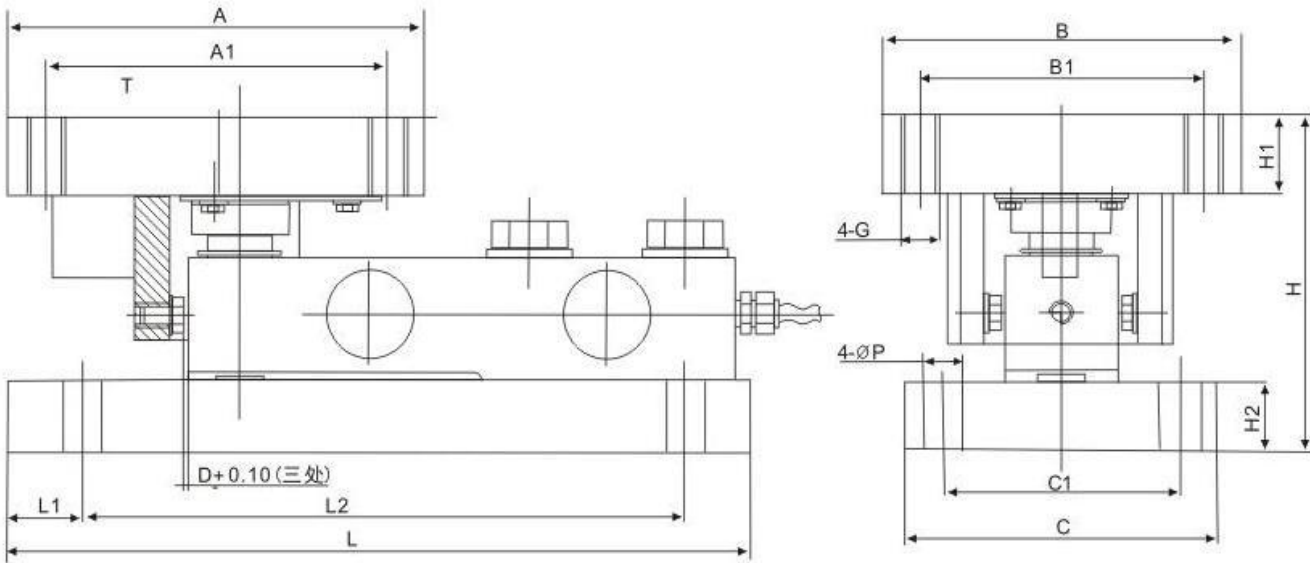

OIML Single Point Ended Shear Beam Load Cells SB



额定载荷(t) Rated Load	模块主要外形及安装尺寸															
	A	A1	B	B1	L	L1	L2	C	C1	H	H1	H2	D	G	P	
0.3-3	150	124	128	102	286	32	226	112	80	107	23	23	1.6	M10	13	
5.7,5,8	178	146	152	120	317.5	32	257	152	102	146	32.5	29	1.6	M16	17	
10	184	152	154	122	360	32	295	154	106	216	44	44	3	M20	21	
15-25	220	170	220	170	400	25	350	220	170	252	54	54	3	M24	26	

静载模块安装方式

Static weighing module installation

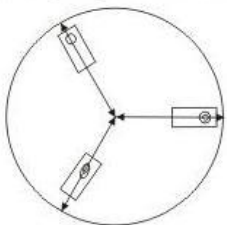

径向安装Radial mouting

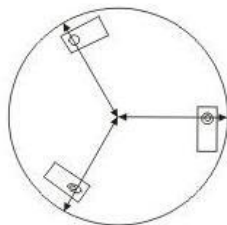

切向安装Cutting mouting

- 固定式Fixed Module
- ⊕ 全浮动式Float Module
- ⊖ 半浮动式Semi-float Module

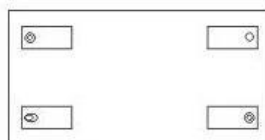

矩形安装Rectang mouting

动载模块安装方式

Dynamic weighing module installation



## Wiring Diagram

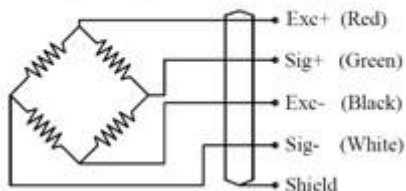

## Specification

Application	Truck Scales, Platform Scales, Blending Scales
Rated Load	0.3, 0.5, 1, 2, 3, 5, 7.5, 8,10, 15, 20, 25t
Temperature Range. Compensated:	-10~+40℃
Sensitivity	2±0.002mV/V
Zero balance	±1%F.S
Operating Temp Range	-30~+70℃
Input resistance	400±10Ω
Output resistance	352±3Ω
Insulation resistance	≥5000MΩ
Accuracy Class	C2-C5
Safe Load Limit	150%F.S, 120%F.S (20-25t)
Over Load Limit	250%F.S, 200%F.S (20-25t)
Recommend Excitation	10~12V DC
TCO	±0.02%F.S/10℃
TC SPAN	±0.02%F.S/10℃
Maximum excitation	15V DC
Protection Class	IP67(0.3-0.5t) IP68 (1-25t)
Construction	Alloy Steel-S/-SS;Stainless steel
Cable: Length	2.6m(0.3-2t), 3.5m(3t),5.2m(5-8t), 7m(8-10t), 12m (15-25t)
Diameter	Φ5mm(0.3-8t), Φ6mm(10-25t)