

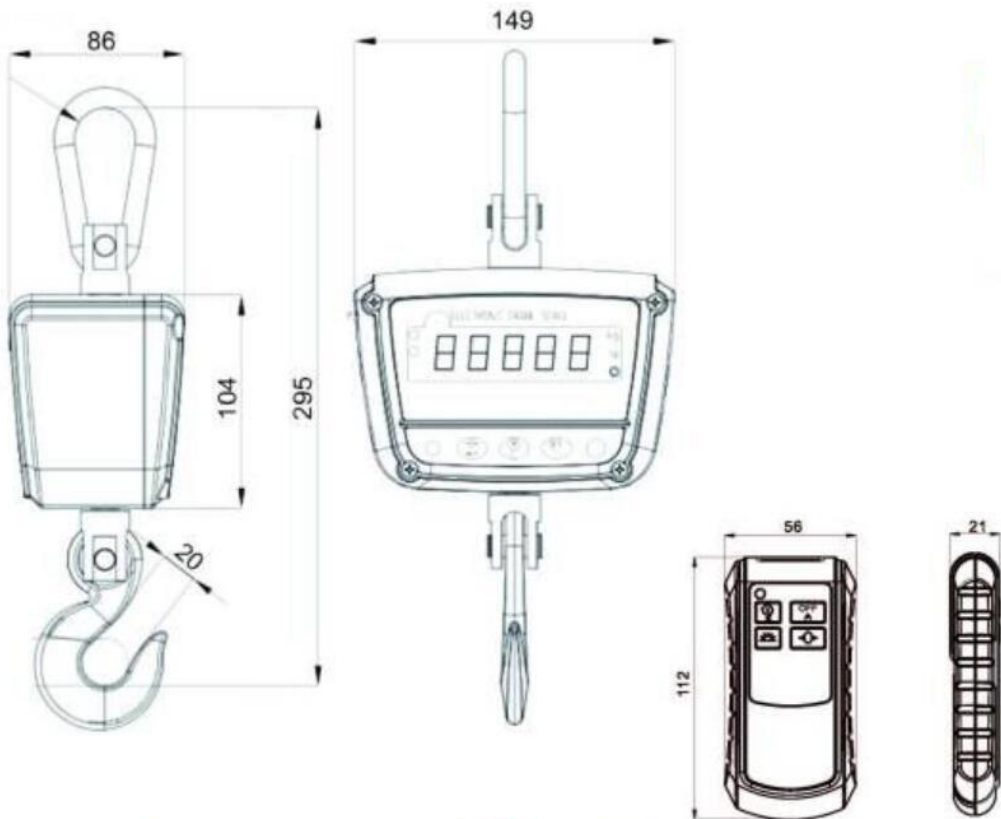

Digital Waterproof Crane Scale OCS-XZ-GGE-PLUX



kN
lb **kg**
selectable

Built-in beeper

IP65
Water proof grade

Battery

High precision

Capacity(:mm)

Max Capacity	Division	Weight
30kg	0.01/0.005kg	2kg
50kg	0.02/0.01kg	2kg
100kg	0.05/0.02kg	2kg
150kg	0.05/0.02kg	2kg
200kg	0.1/0.05kg	2kg
300kg	0.1/0.05kg	2kg

Noted: The optional division is only for reference but not for verification

Feature:

High Strength Aluminum die-casting shell, strong, beautiful and light, waterproof and dust-proof

Convenient 360 swivel shackle and hook

IP65 industrial grade to protect from extremely environment

Special Alloy Steel Sensor , high precision , high resolution

Built-in rechargeable long-life lithium iron battery , the perfect combination

Of new energy and energy-saving technology

Technical Parameter:

Accuracy : OIMLR76 C3

Maximum Safe Load :150%F.S.

Overload Alarm :100% F.S.+9e

Time to Stable Reading ≤8s

Limited Overload : 400% F.S.

Operating Temperature : -10℃ -+55℃