

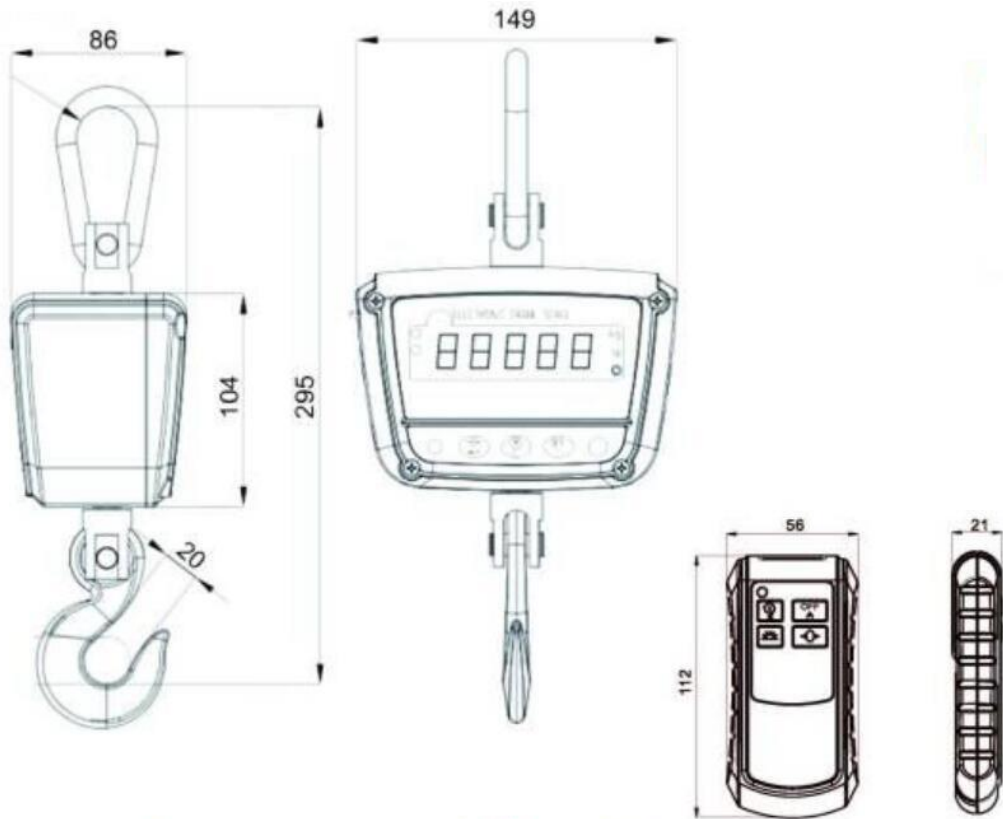

### Digital Waterproof Crane Scale OCS-XZ-GGC-PLUX



kN  
lb kg

selectable



Built-in beeper

IP65

Water proof grade



Battery



High precision

**Capacity(:mm)**

Max Capacity	Division	Weight
30kg	0.01/0.005kg	2kg
50kg	0.02/0.01kg	2kg
100kg	0.05/0.02kg	2kg
150kg	0.05/0.02kg	2kg
200kg	0.1/0.05kg	2kg
300kg	0.1/0.05kg	2kg

Noted: The optional division is only for reference but not for verification

**Feature:**

High Strength Aluminum die-casting shell, strong, beautiful and light, waterproof and dust-proof

Convenient 360 swivel shackle and hook

IP65 industrial grade to protect from extremely environment

Special Alloy Steel Sensor , high precision , high resolution

Built-in rechargeable long-life lithium iron battery , the perfect combination

Of new energy and energy-saving technology

**Technical Parameter:**

Accuracy : OIMLR76 C3

Maximum Safe Load :150%F.S.

Overload Alarm :100% F.S.+9e

Time to Stable Reading ≤8s

Limited Overload : 400% F.S.

Operating Temperature : -10℃ -+55℃

ADD: UNIT 615A 6F ZHONG TIE FORTUNE PLAZA NO.398 JIAHE ROAD XIAMEN FUJIAN CHINA

TEL:86-592-6686182, Email:sales@kuanyi.com, <http://www.kuanyi.com>.