



Wireless Crane Scale OCS-SZ-KPII



Feature:

- Capacity: 1t, 2t, 3t, 5t,10t,15t,20t,30t, 50t
- New designed K series scale , sturdy and portable
- Impact resistant all steel construction for RFI protection
- Long life environmental LFP battery for scale

Technical Parameter:

- Accuracy : OIMLR76 C3
- Maximum Safe Load :150%F.S.
- Overload Alarm :100% F.S.+9e
- Time to Stable Reading $\leq 8s$
- Limited Overload : 400% F.S.
- Operating Temperature : -10 $^{\circ}C$ --+55 $^{\circ}C$

Optional Indicator:



Bluetooth function
PIII Indicator



Wireless indicator
CII Indicator



Optional 5-inch wired / wireless screen

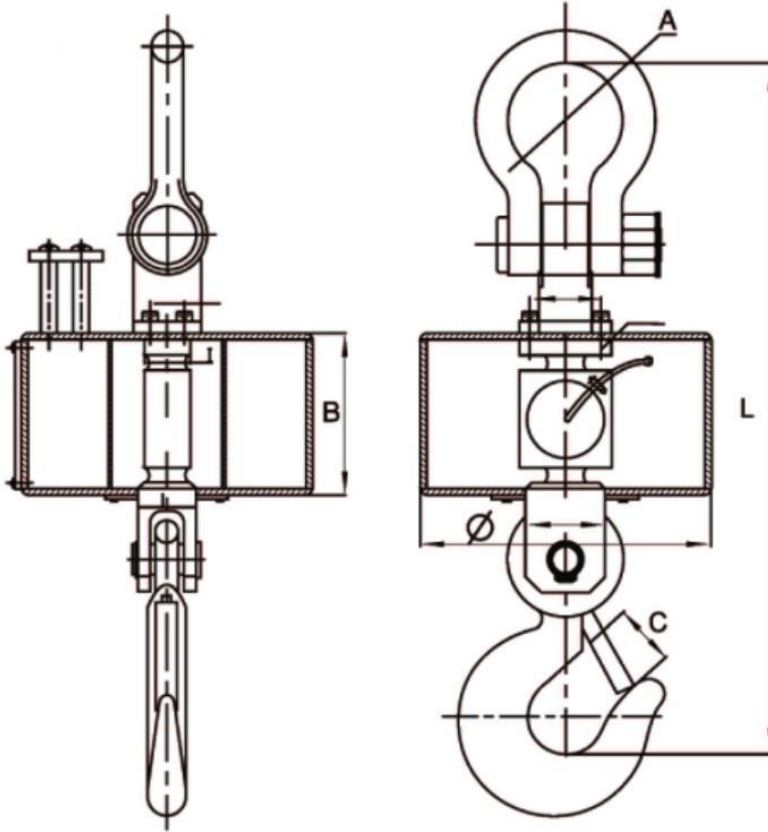

Capacity: mm

Max Capacity	A	B	C	Φ	L	Weight
1T	76	125	40	240	467	15kg
2T	76	125	40	240	467	15kg
3T	76	125	40	240	467	15kg
5T	80	125	50	240	536	23kg
10T	90	130	54	263	610	36kg
15T	135	141	60	263	729	52kg
20T	150	148	73	295	811	65kg

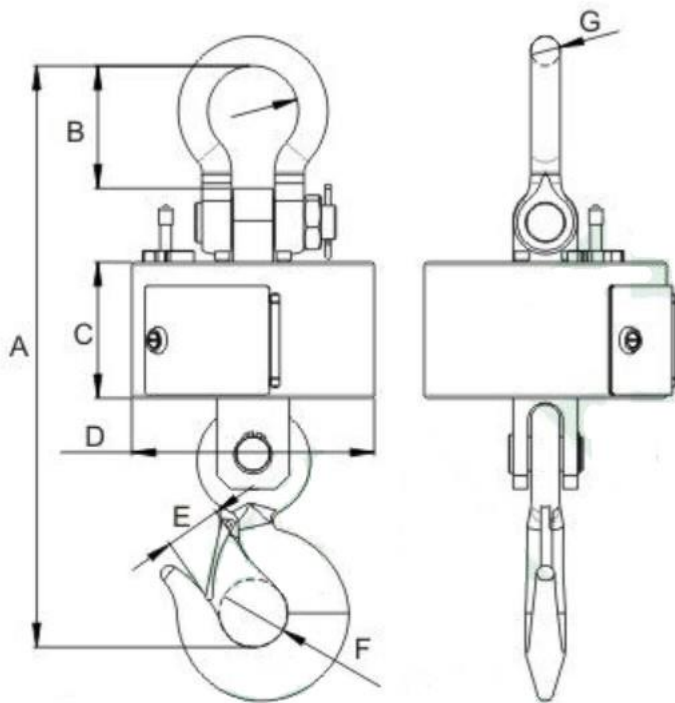

MM :

Max Capacity	A	B	C	D	E	F	G	H
3T	453	94	120	Φ214	40	Φ50	Φ23	R38
5T	512	108	120	Φ214	50	Φ60	Φ26	R40
10T	608	129	130	Φ240	52	Φ70	Φ36	R45
15T	704	179	130	Φ263	57	Φ85	Φ47	R67
20T	811	198	150	Φ263	73	Φ90	Φ51	R75
30T	992	247	150	Φ294	120	Φ130	Φ65	R75
50T	1213	273	210	Φ375	130	Φ150	Φ72	R107

30T Net Weight: 128kgs

50T Net Weight: 259kgs