



Mini Bluetooth LCD Display Crane Scale OCS-L



Features:

- Capacity: 30kg to 300kg
- Die-casting aluminum enclosure
- 20mm LCD display with backlight
- Stainless steel shackle
- Stainless steel hook
- AA*3 Battery
- Waterproof panel button
- Various color available
- Bluetooth (optional)

Function:

- Zero
- Tare In /Tare Out
- Hold
- Low Voltage Auto Power-off
- Battery Supervision
- Overload Alarm
- Kg/lb/ N Conversion

More photos and Drawing

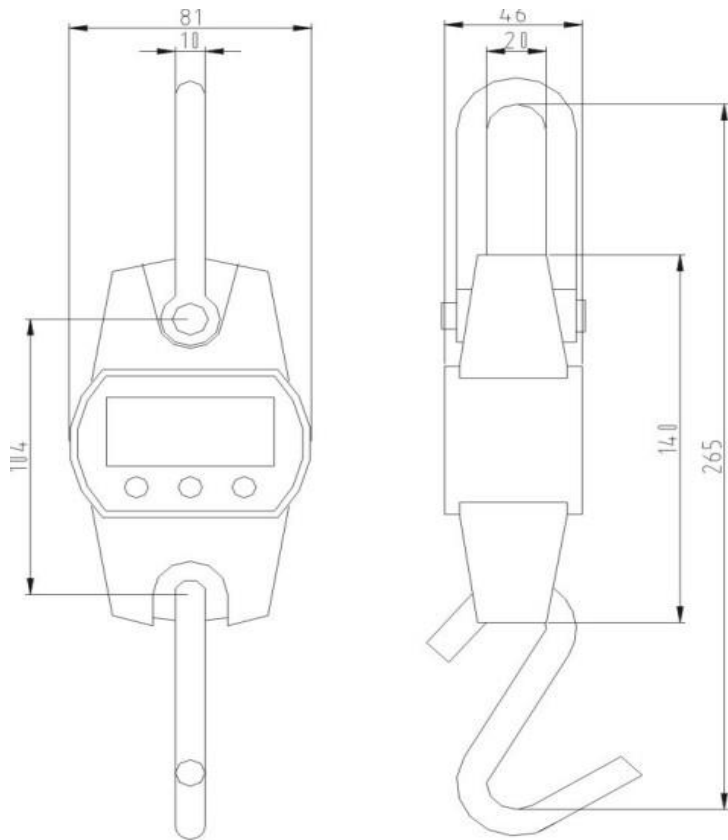

规格和分度 Capacity and Division

最大称量 Max. Cap.		最小称量 Min. Cap.		分度值 E		分度数 Resolution n
(kg)	(lb)	(kg)	(lb)	(kg)	(lb)	
30	60	0.2	0.4	0.01	0.02	3000
50	100	0.4	1	0.02	0.05	2500
60	120	0.4	1	0.02	0.05	3000
100	200	1	2	0.05	0.1	2000
120	240	1	2	0.05	0.1	2400
150	300	1	2	0.05	0.1	3000
200	400	2	4	0.1	0.2	2000
300	600	2	4	0.1	0.2	3000

主要技术指标 Specification

准确度等级	Accuracy Class	OIML III 级
去皮范围	Tare Range	100%F.S.
置零范围	Zero Range	4%F.S.
安全载荷	Safe Overload	120%F.S.
极限载荷	Ultimate Overload	300%F.S.
超载报警值	Overload Alarm	100%F.S.+9e
电池规格	Battery	1.5V AA×3
连续使用时间	Battery Life	>150h
温度范围	Temperature Range	-10℃~40℃
净重	Net Weight	620g