

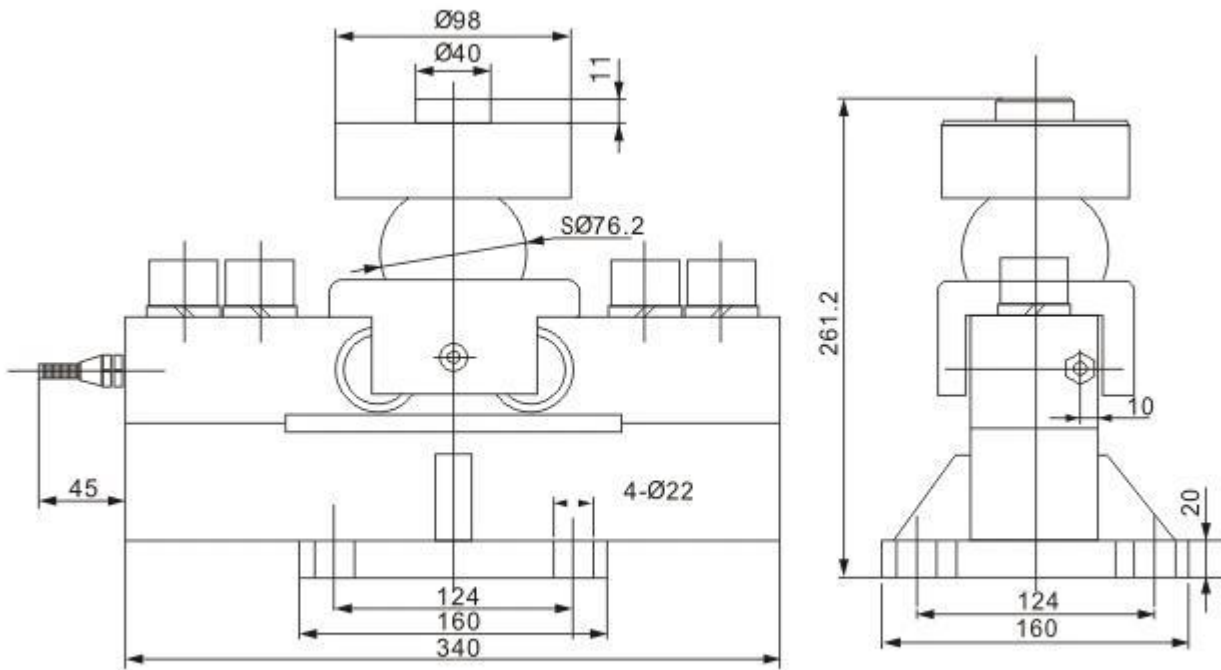

### OIML Double Ended Shear Beam Load Cells BSB



50t



#### Wiring Diagram

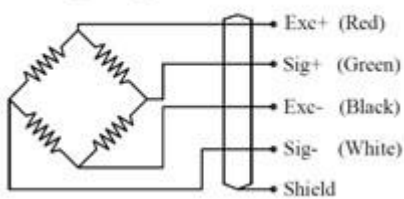

## Specification

Application	Truck Scales, Railway Scales, Blending Scales ,Special scales
Rated Load	50T
Sensitivity	2.0±0.002mV/V
Accuracy Class	C1-C5
Zero balance	±1%F.S
Input resistance	750±10Ω
Output resistance	702±3Ω,703±5Ω(L≥15M)
Insulation resistance	≥5000MΩ
Operating Temp Range	-30~+70℃
TCO	±0.02%F.S/10℃
TC SPAN	±0.02%F.S/10℃
Safe load limit	150%F.S, 120%F.S ( 40-50T)
Recommend excitation	10~12V DC
Maximum excitation	15V
Protection Class	IP67(5T)/IP68(10-40T)
Construction	Alloy Steel /Stainless Steel
Cable Length	16m(40-50t) Diameter:Φ6mm