

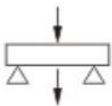

### OIML Double Ended Shear Beam Load Cells BSA

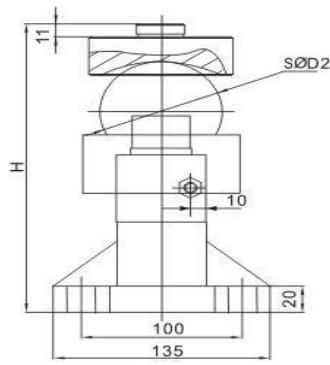

5~40t

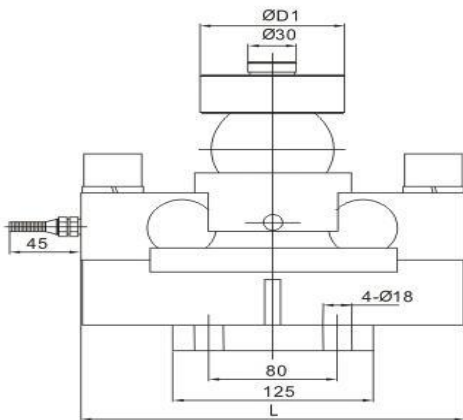

额定载荷(t) Rated Load	5	10,15,20,25,30	40
D1	68	85~88	88
D2	50.8	76.2	76.2
H	168.8	224.7	230.7
L	224	240	240

#### Wiring Diagram

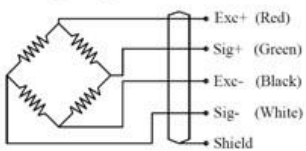

**Specification**

Application	Truck Scales,Railway Scales, Blending Scales , Special scales
Rated Load	5, 10,15,20,25,30, 40T
Sensitivity	2.0±0.002mV/V
Accuracy Class	C1-C5
Creep(30min)	±0.02%F.S
Zero balance	±1%F.S
TCO	±0.02%F.S/10℃
TC SPAN	±0.02%F.S/10℃
Input resistance	750±10Ω
Output resistance	702±3Ω, 703±5Ω(L≥15M),
Recommend excitation	10~12V DC
Maximum excitation	15V DC
Insulation resistance	≥5000MΩ
Protection Class	IP67(5T)/IP68(10-40T)
Temperature Range. Compensated:	-10~+40℃
Operating Temp Range	-30~+70℃
Safe load limit	150%F.S, 120%F.S ( 40-50T)
Construction	Alloy Steel-S/-SS;Stainless steel
Over load limit	300%F.S. 200%F.S ( 40-50T)
Cable	Length;5.2m(5t),10m(15t) ,10/12m(20t)
	12/15m(25t), 12/16m(30t), 16m(40t) Diameter:Φ6mm